



**DCAI**  
Department of Cybernetics  
and Artificial Intelligence

# CENTER OF MODERN CONTROL TECHNIQUES A INDUSTRIAL INFORMATICS

---

WORKING WITHIN **DEPARTMENT OF CYBERNETICS AND ARTIFICIAL INTELLIGENCE**, TU KOŠICE

**doc. Ing. Ján Jadlovský, CSc.**  
Head of the CMCT & II

Technical university of Košice  
Faculty of Faculty of Electrical Engineering and Informatics  
Department of Cybernetics and Artificial Intelligence

# Center of Modern Control Techniques and Industrial Informatics within DCAI

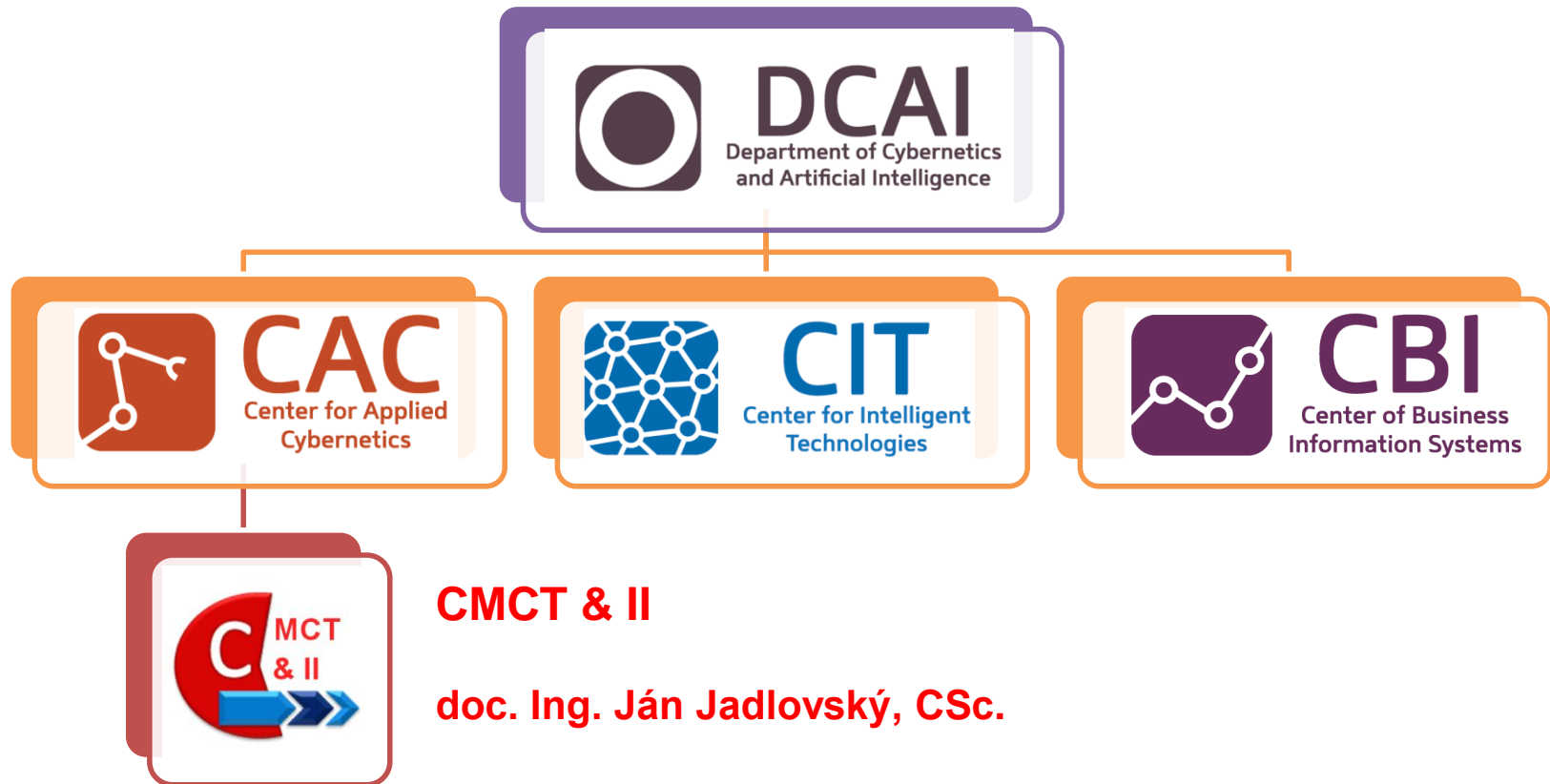



# Center of Modern Control Techniques and Industrial Informatics

Department of cybernetics and artificial intelligence (DCAI), FEI, Technical University of Košice

Profile

Infrastructure

Laboratories

Members

Courses

Models

Research

CERN

Gallery

Partners



Profile

Infrastructure

Laboratories

Members

Courses

Models

Research

CERN

Gallery

Partners

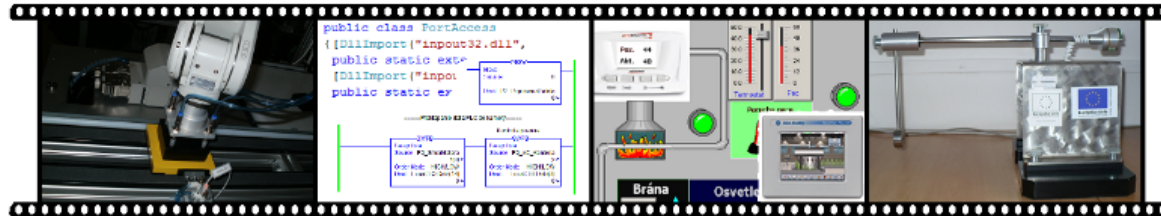

## Profile of the Center of Modern Control Techniques and Industrial Informatics

- » We are a university research center focused on teaching and research in the field of advanced control techniques and industrial automation.
- » We are equipped with the most up-to-date resources for development, simulation and implementation for regulation, control, information, management and communication systems.
- » Technical, program and network resources were supplied by the world's leading companies in information technology and management (Rockwell Automation, Wonderware, Oracle, Mitsubishi, Mathworks and others.) which provide regular updates as well.
- » The supplied resources have been arranged into the 5-level DCS pyramid model in accordance with the international CIM standard (Computer Integrated Manufacturing), which ensures the implementation of a fully-automated control system for production companies.
- » All research and development of control system components is conducted based on the 5-level DCS pyramid model.
- » The obtained results are applied in the curriculum of courses for bachelor and master studies, in the base research and in solving practical problems in manufacturing plants.

### Recent news:

kyb.fei.tuke.sk/lab/en

# CMCT & II

- research center focuses on education and research in the field of modern methods of control and industrial automation
- CMCT & II is equipped with the latest development, simulation and implementation tools used in control, information systems, management information systems and communication systems
- the results are applied in the educational process of subjects of Bachelor and Master studies, in basic research of FEEI and in solving practical problems in manufacturing enterprises
- based on the five-level pyramid model of DCS (Distributed Control Systems), research and development of different parts of the DCAI control system are realized

# Infrastructure of the DCS in DCAI

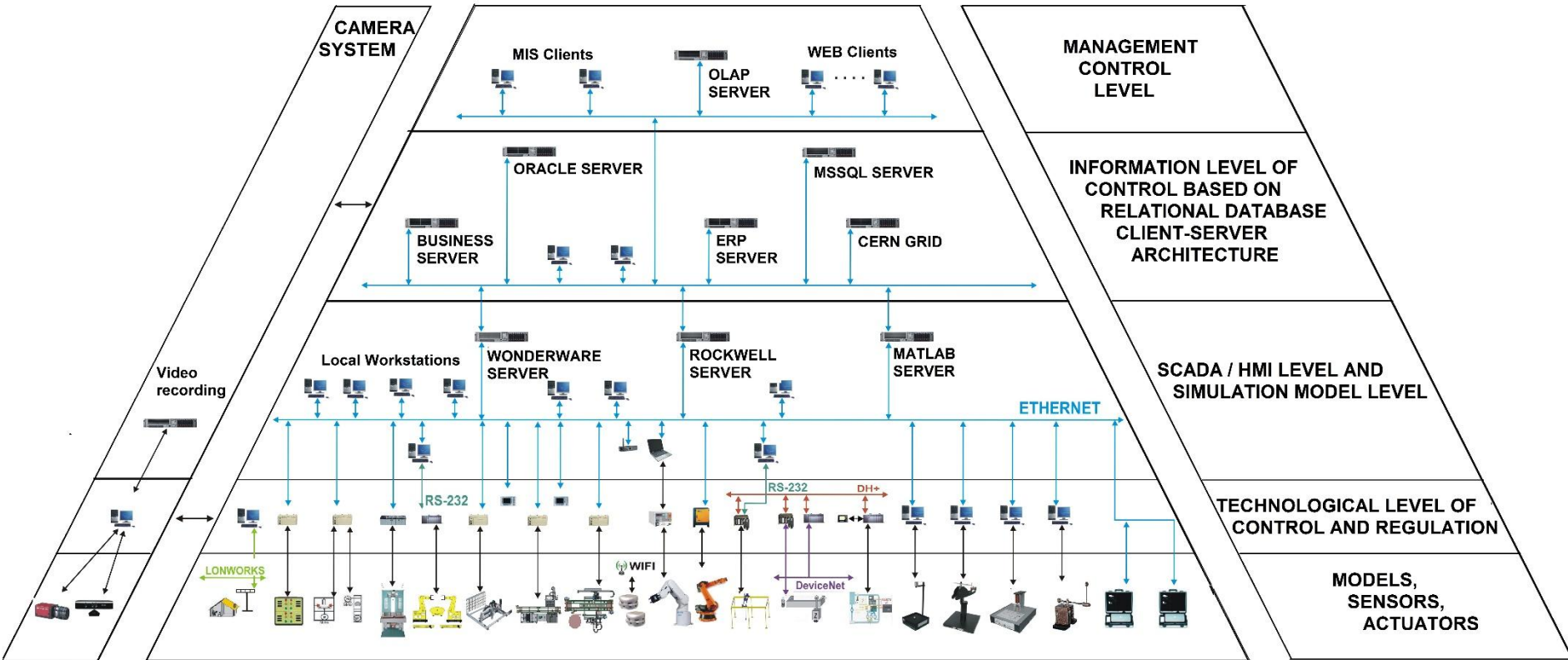

# Laboratories of CMCT & II

CMCT & II

Laboratory of Mechatronic Systems (V142)

Laboratory of Technological Process Control (V144)

Laboratory of Computer Control System Design  
(V101b)

Laboratory of Production Lines and Image  
Recognition (V147)

Laboratory of Robotics (V134)



# Selected laboratory models of CMCT & II

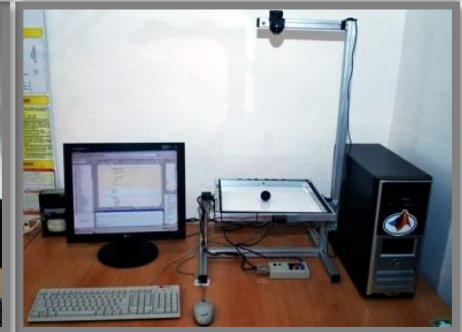
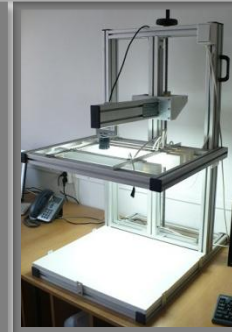
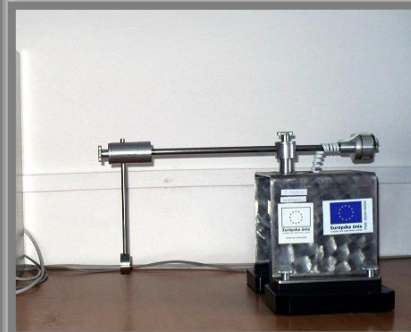

Partners of CMCT & II

**Rockwell**  
**Automation**

**ORACLE®**

 **MathWorks®**

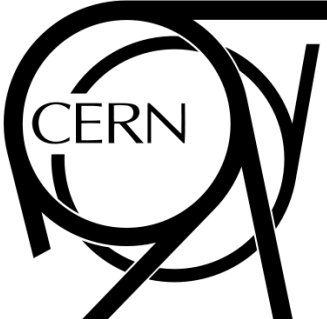
 **CERN**

**Wonderware®**  
invensys™

 **HUMUSOFT®**



# COOPETARION OF FEEI - TU KOŠICE WITH CERN ON ALICE EXPERIMENT

Project: Experiment ALICE on LHC in CERN : Study of strongly interacting matter at extreme energy densities

Project status: Basic research

Research and development field: Nuclear and sub-nuclear physics

---

responsible researcher in FEEI - TUKE: doc. Ing. Ján Jadlovský, CSc.

# TU Košice cooperation on project ALICE-CERN

**October  
2012**

- TU Košice was accepted as **associate** member of **ALICE CERN** collaboration

**September  
2014**

- TU Košice was accepted as **full** member of **ALICE CERN** collaboration

**June  
2015**

- was accepted as **associate** member of **HepTech** - *High-Energy Physics Technology Transfer Network Board*

ITS innovation is focused on Pixel Detector development with the request to identification of particles trajectories (particles positions), which are product of the Pb-Pb collisions with energy 4 TeV to n-n pair.

### **Solved tasks in project:**

1. Control of Pixel Detector
2. Hybrid Integrated Circuit (HIC) development designed for acquisition and processing of signals received from ALICE detectors
3. Development of program modules for control and communication infrastructure of DCS

# Basic parts of DCS (Detector Control System)

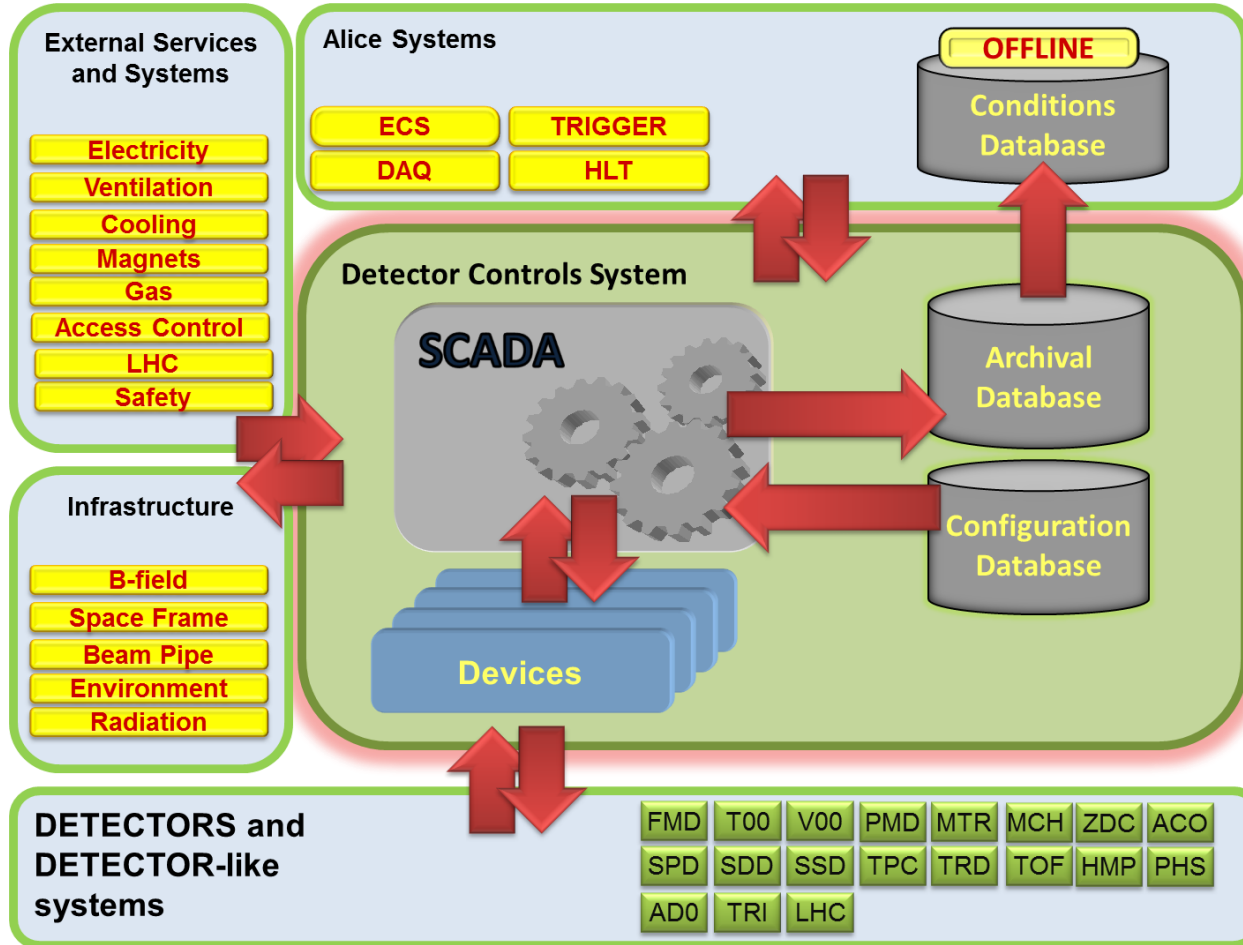



# Solved tasks in the project

Tasks at RDBS Oracle level dealing with configuring the parameters of the experiment from the configuration database and archiving data into the archival database

Tasks for sequence control of pixel detectors and their protection from destruction at WinCC OA level

Communication between different levels of control system realized for including the control system of pixel detectors into the infrastructure of DCS ALICE

communication module between DCS & sensors and algorithms of data collection from sensors which will be provided in the form of a hybrid integrated circuits after finish of development, generally designed for data acquisition and control detectors at CERN

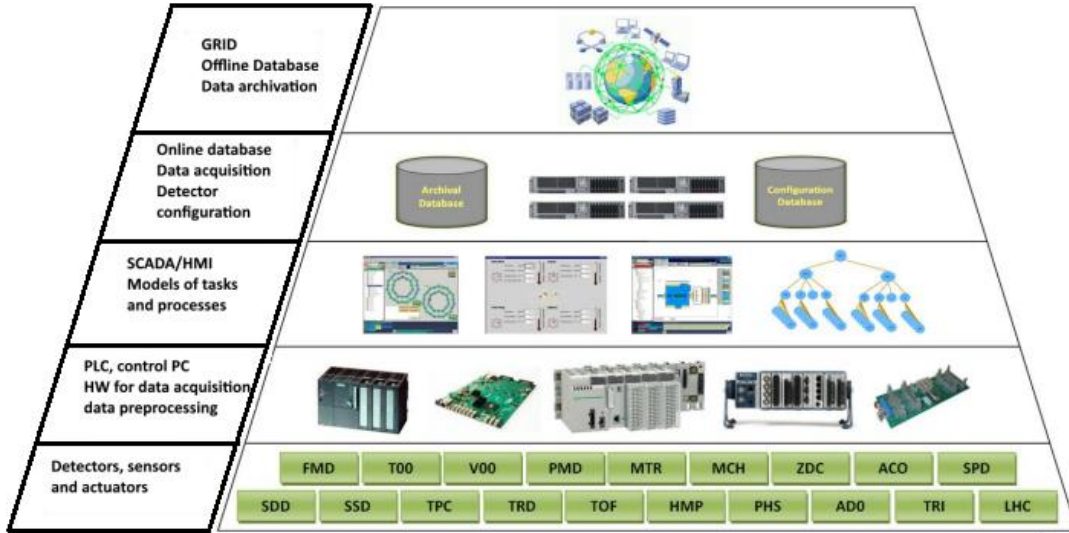

Interconnection  
between  
DCS ALICE and DCS  
in DCAI

Real-time connection  
with CERN

Connection  
DCS in KKUI  
and DCS ALICE  
CERN

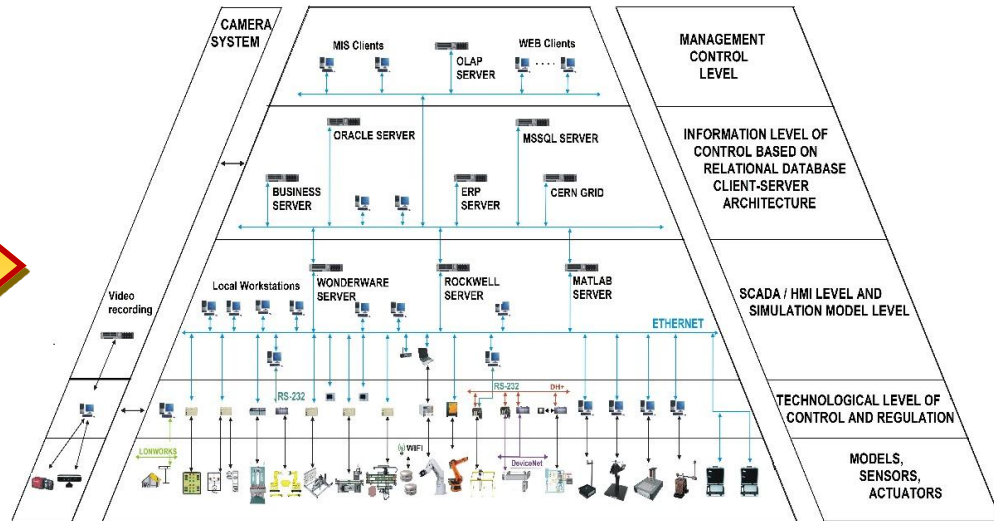
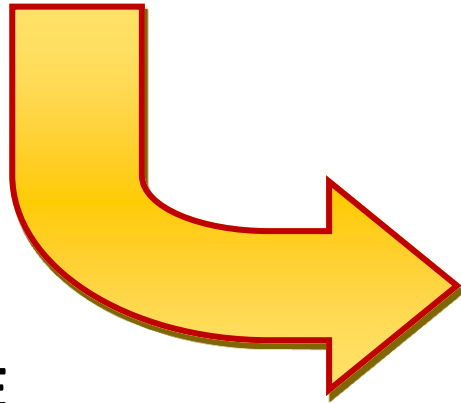

# Alice DCS

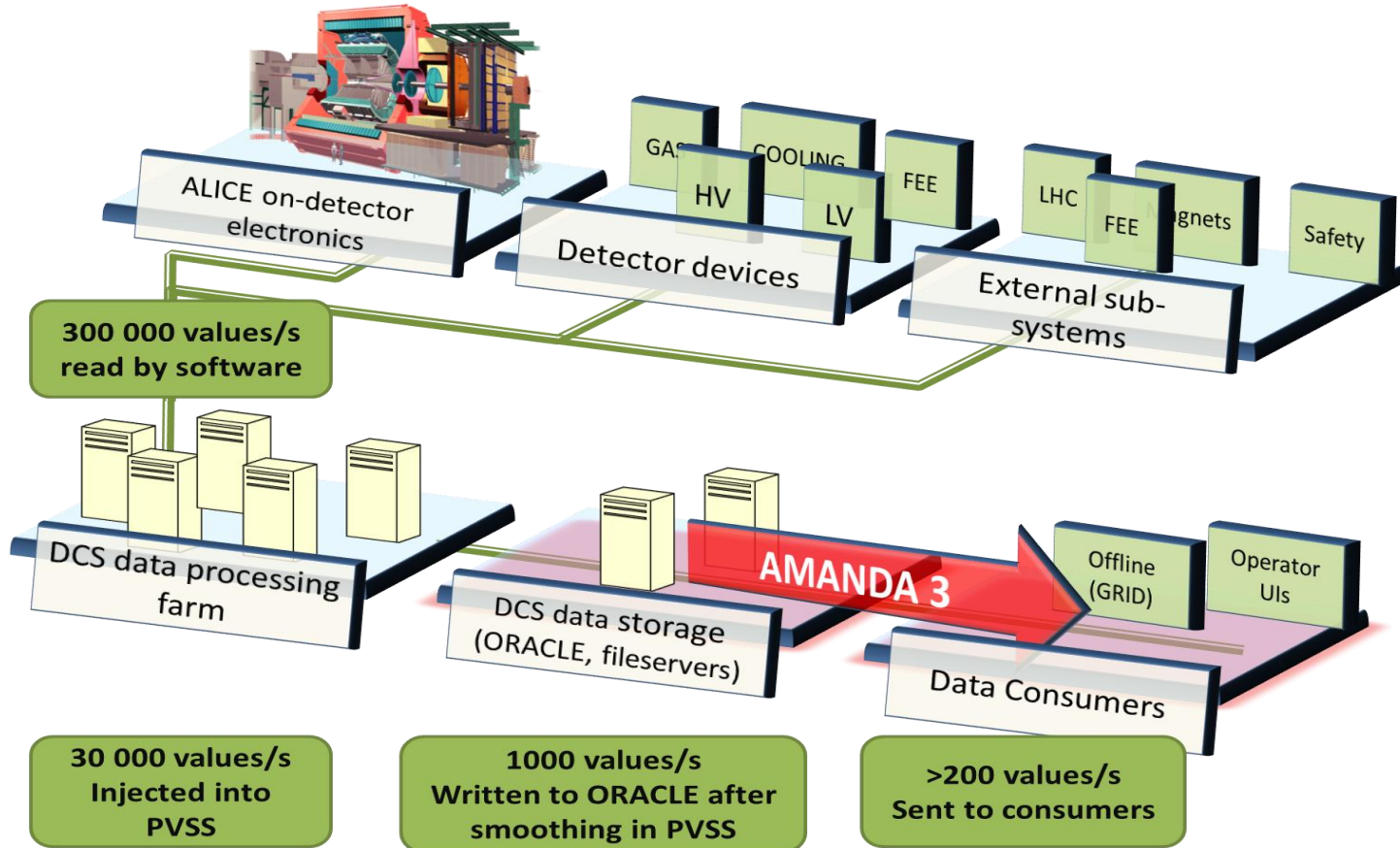



# ALICE DCS – AMANDA 3 IS

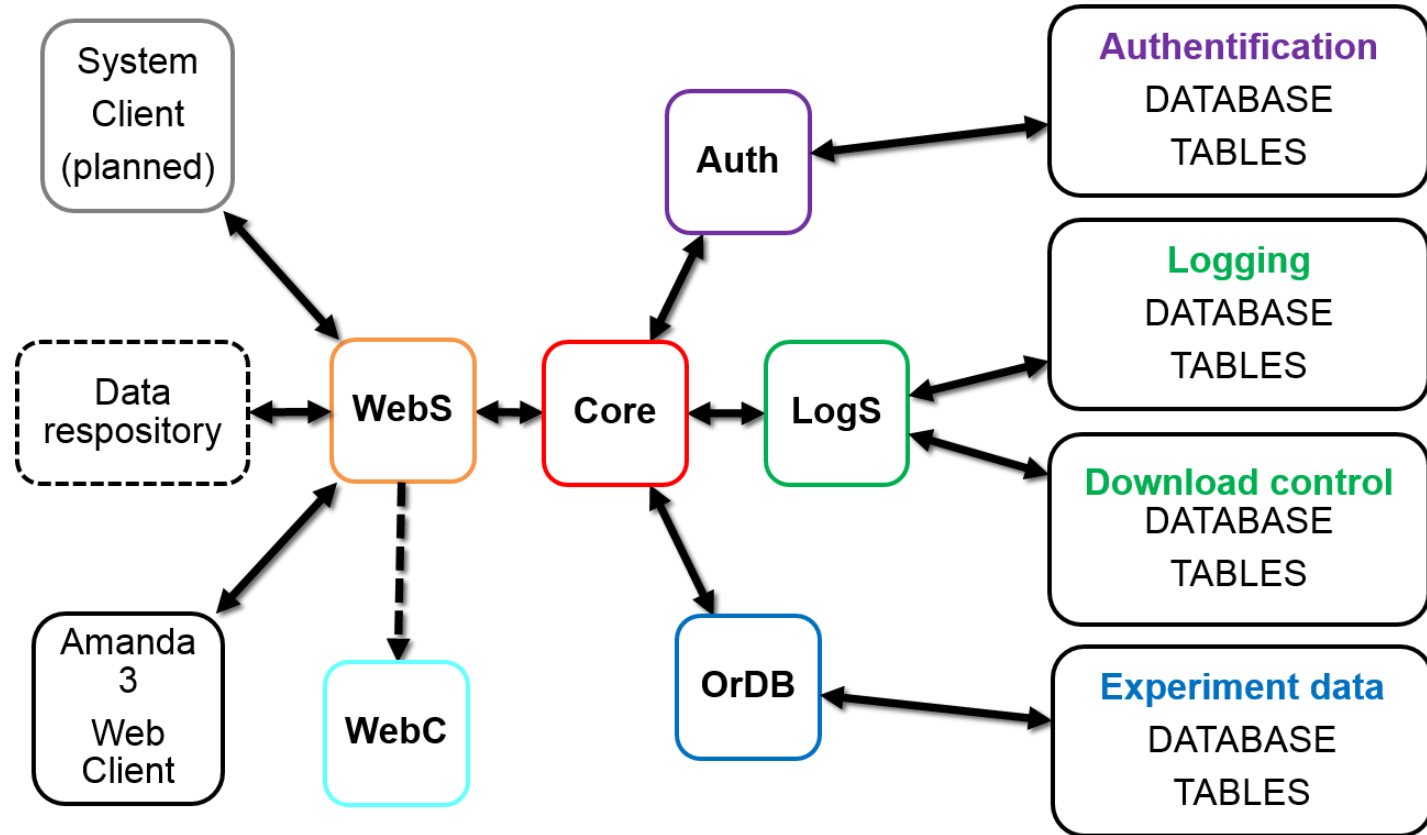

# Detector ALICE

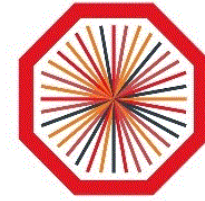

**ALICE**

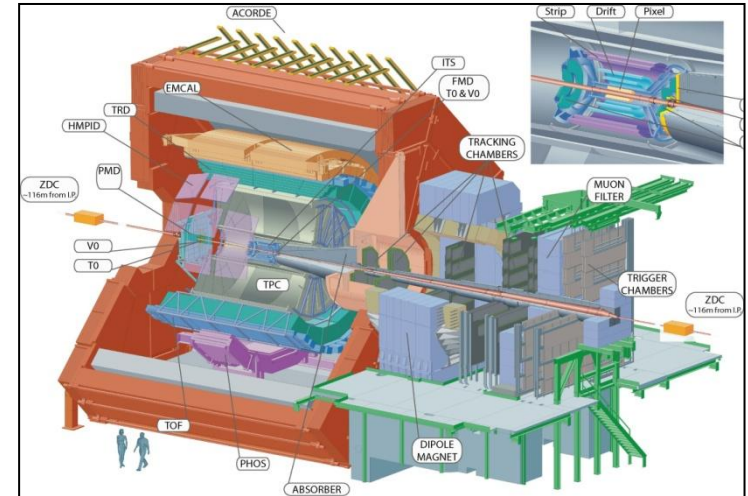
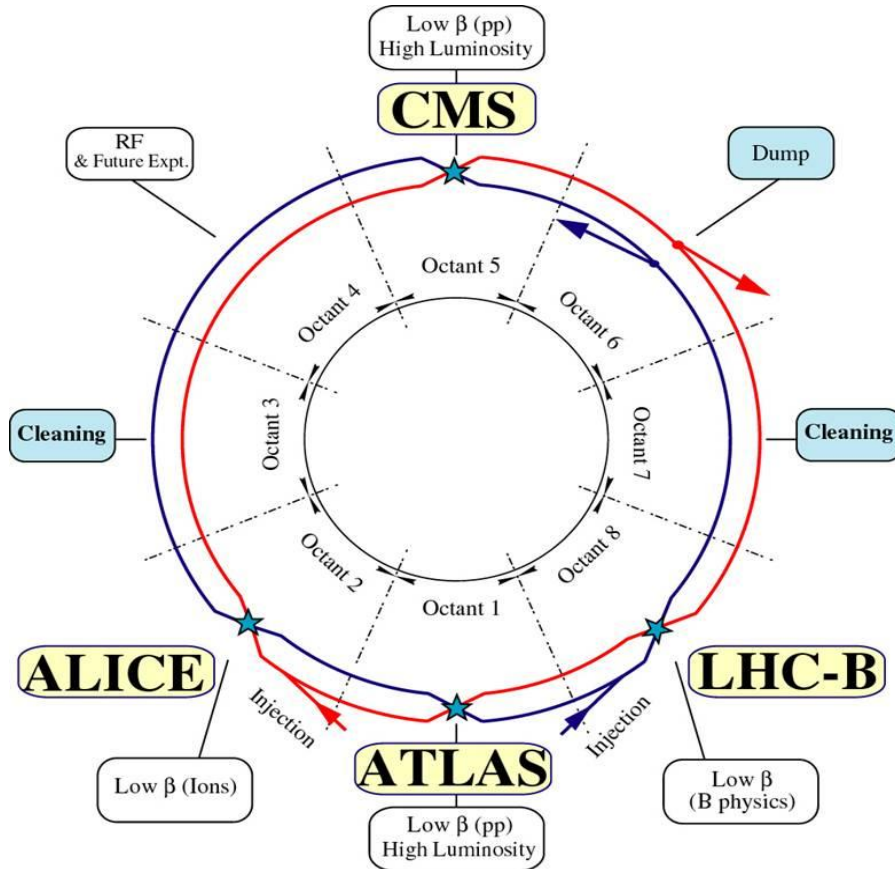

# Upgrade of the ALICE Inner Tracking System

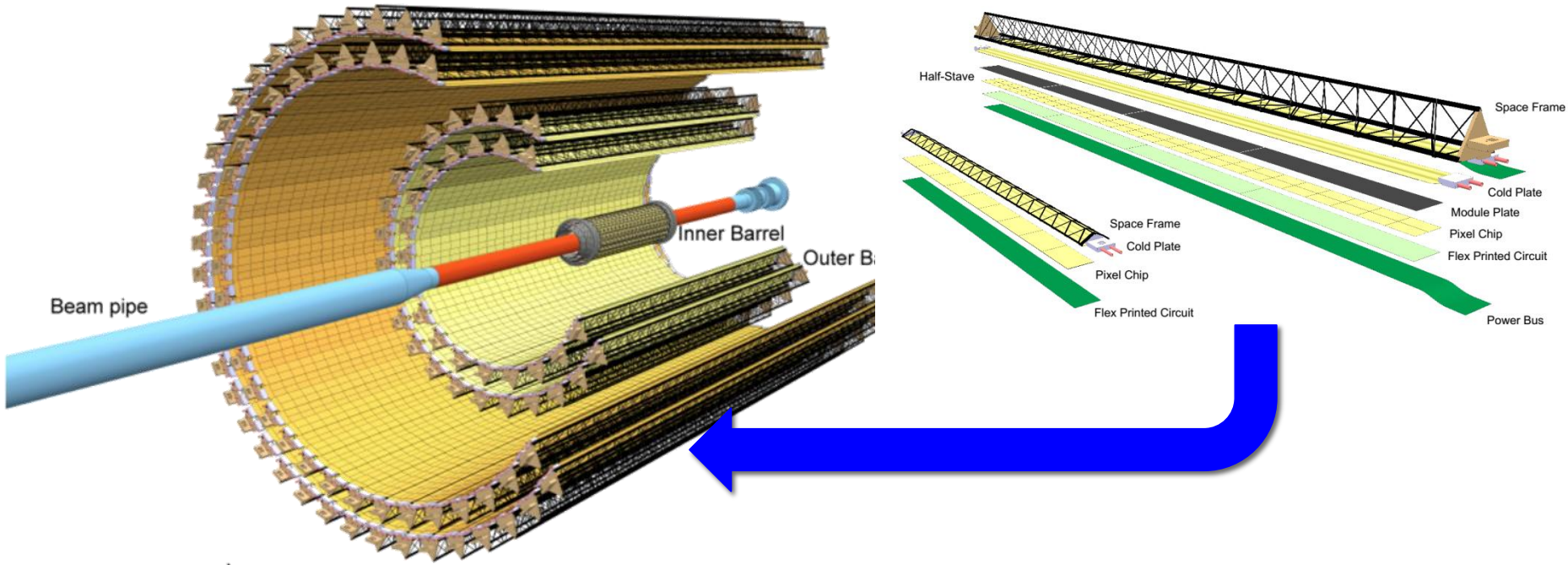

PIXEL DETECTOR

# Testing workplace of Hybrid Integrated Circuit (HIC)

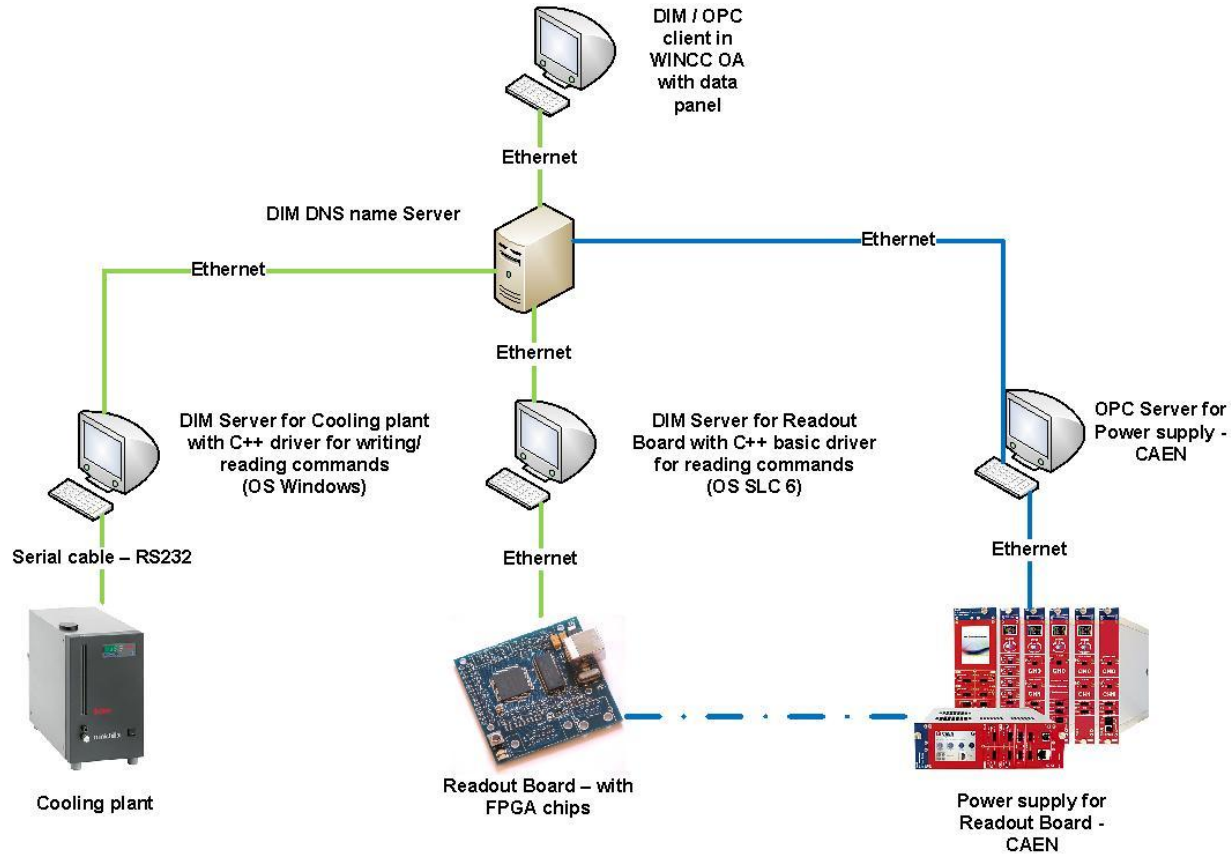

# Infrastructure of models of developed DCS

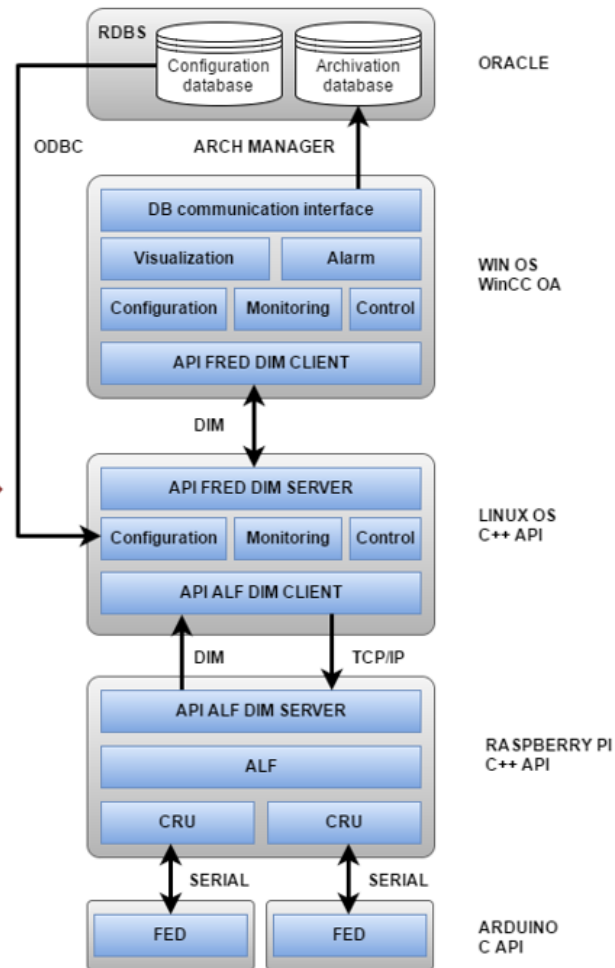
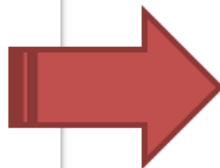
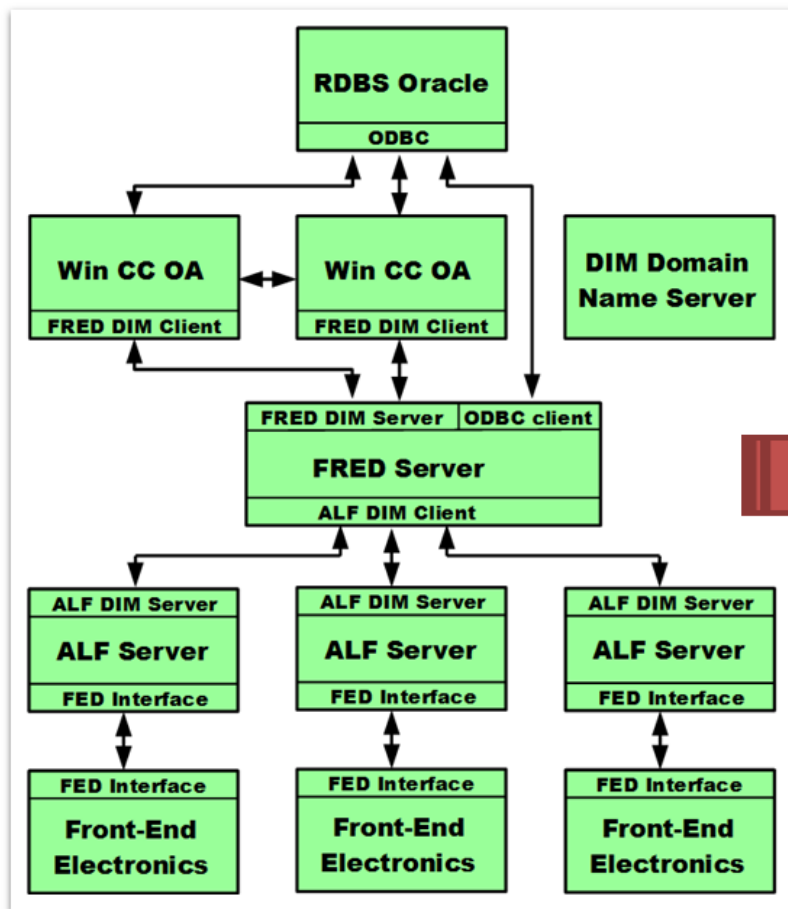

# Laboratory workplace for connecting the sensors into DCS infrastructure

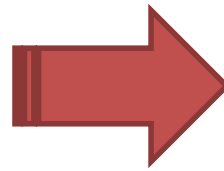
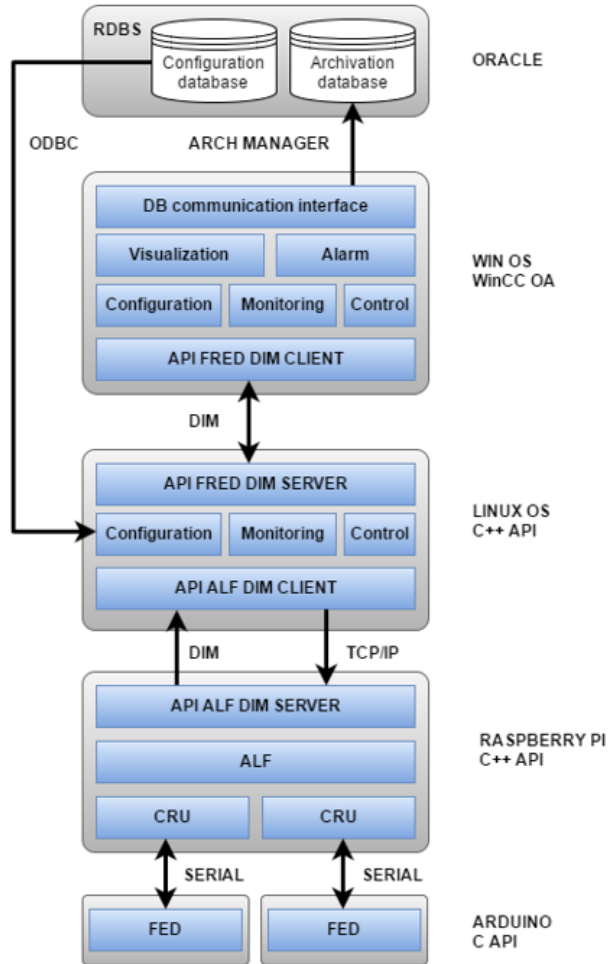

PROJECT OF APPLIED RESEARCH

TECHNICOM

---

# Infrastructure of DCS in DCAI

## INFRASTRUCTURE KKUI

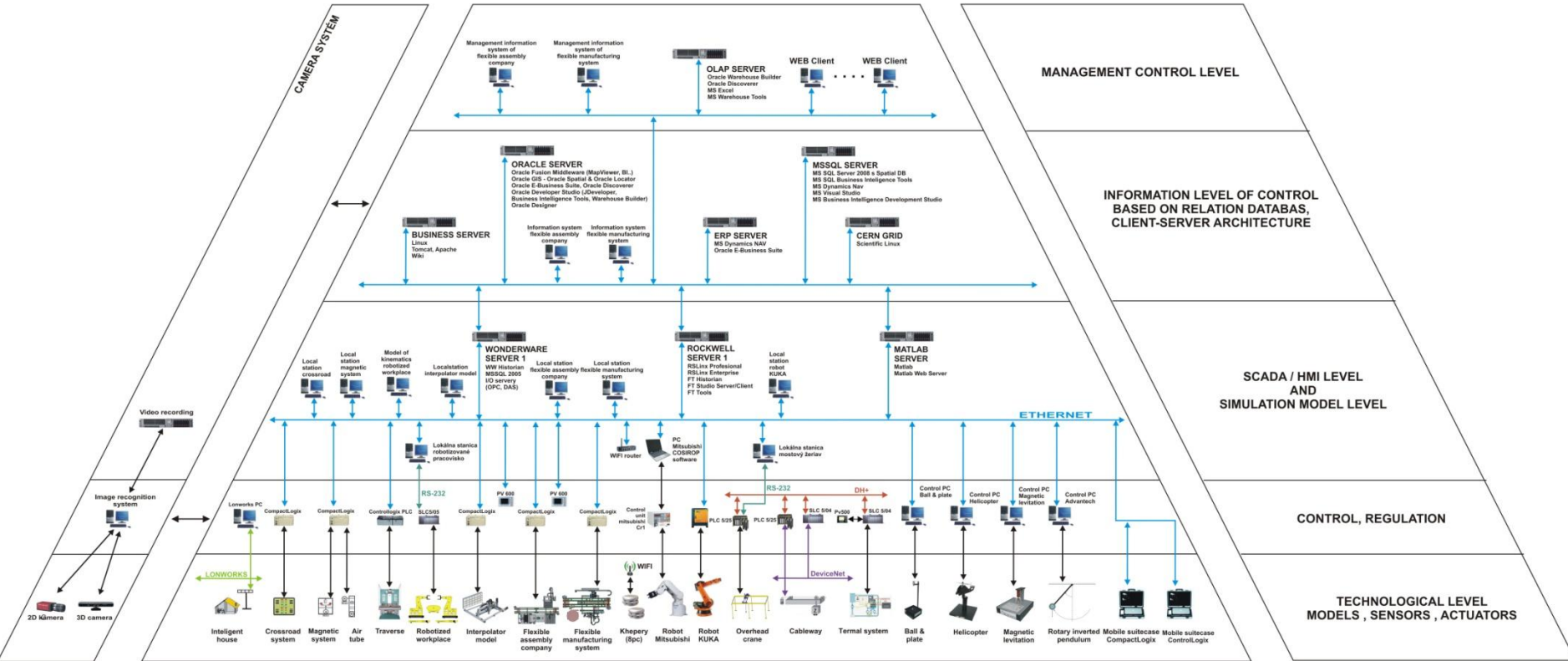



# Project TECHNICOM

## Center of non destructive diagnostics of technological processes

- output of the project is functional methodology workplace with focus on solving of tasks from field of modeling, control and diagnostics of technological processes using non destructive techniques.
- one of the forms from project TECHNICOM outputs for part “Center of non destructive diagnostics” is set of model applications, that are divided into following parts

# Areas of applied research

## Model applications with the implementation of camera systems

- Simulation of matter state transitions
- Guidance of Mitsubishi Melfa manipulator
- Quality control in FMS
- Intelligent positioning surface
- Guidance in robotic soccer and maze
- Workplace of non destructive diagnostics with linear drive
- Monitoring and diagnostics of thermodynamic processes based on thermo vision camera

## Model applications for mechatronic systems

- Rotary inverted pendulum
- Intelligent positioning surface
- Workplace of non destructive diagnostics with linear drive – classical inverted pendulum
- Library of simulation models for under actuated systems
- Hydraulic system with frequency converter

## Model applications for mobile robotics

- Diagnostics of sensors and actuators of robotic soccer player of MiroSot category
- Manual and supervisory control of mobile robots
- Robotic soccer application
- Library of simulation models for wheeled mobile robots

## Model applications for FAC and FMS

- DCS for flexible manufacturing system
- DSR for automated manufacturing lines – FMS and industrial robot
- Control of robotized manufacturing workplace

# Model applications with the implementation of camera systems

- Simulation of matter state transitions

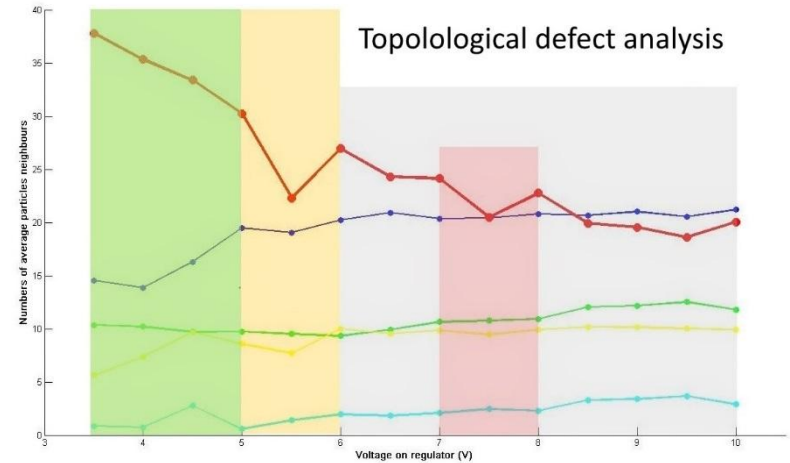
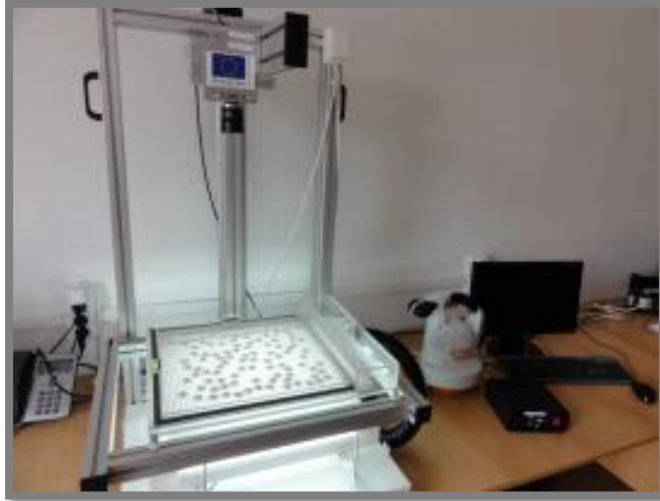
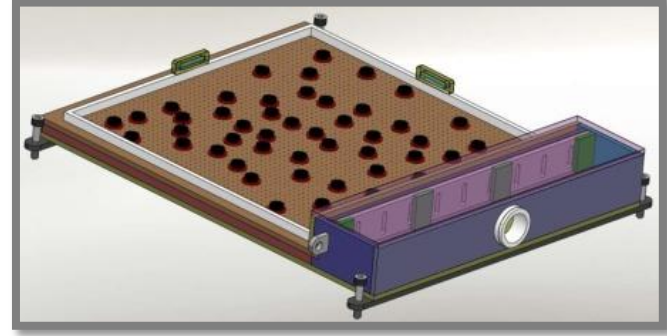

# Model applications with the implementation of camera systems

Guidance of Mitsubishi Melfa manipulator

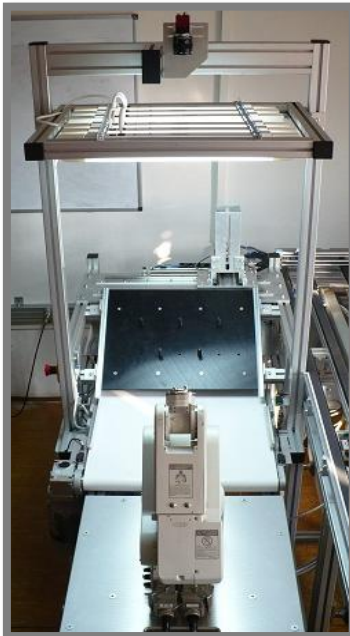

Quality control in flexible manufacturing system

<b>Order ID:</b>	16	<b>Product pattern:</b>	<input type="checkbox"/>	<input type="checkbox"/>	<input type="checkbox"/>	<input type="checkbox"/>	<input type="checkbox"/>
<b>Customer:</b>	Radoslav Medved Kovacska 12 08001 Presov		<input type="checkbox"/>	<input type="checkbox"/>	<input checked="" type="checkbox"/>	<input checked="" type="checkbox"/>	<input type="checkbox"/>
<b>Order status:</b>	Accepted		<input type="checkbox"/>	<input type="checkbox"/>	<input type="checkbox"/>	<input type="checkbox"/>	<input type="checkbox"/>
<b>Price:</b>	58 €		<input type="checkbox"/>	<input checked="" type="checkbox"/>	<input checked="" type="checkbox"/>	<input type="checkbox"/>	<input type="checkbox"/>
<b>Responsible shifter:</b>	Maria Gogolova		<input type="checkbox"/>	<input type="checkbox"/>	<input type="checkbox"/>	<input type="checkbox"/>	<input type="checkbox"/>
<b>Date of sending:</b>	18.5.2015 9:46:35		<input type="checkbox"/>	<input type="checkbox"/>	<input type="checkbox"/>	<input type="checkbox"/>	<input type="checkbox"/>
<b>Date of acceptance:</b>	18.5.2015 11:30:27		<input type="checkbox"/>	<input type="checkbox"/>	<input type="checkbox"/>	<input type="checkbox"/>	<input type="checkbox"/>
<b>Date of processing:</b>			<input type="checkbox"/>	<input type="checkbox"/>	<input type="checkbox"/>	<input type="checkbox"/>	<input type="checkbox"/>
<b>Date of expedition:</b>			<input type="checkbox"/>	<input type="checkbox"/>	<input type="checkbox"/>	<input type="checkbox"/>	<input type="checkbox"/>
			<input type="button" value="OK"/>				

# Model applications with the implementation of camera systems

## Intelligent positioning surface

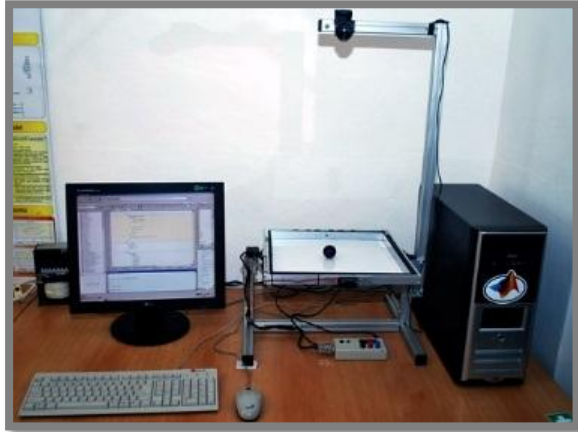

## Guidance in robotic soccer and maze

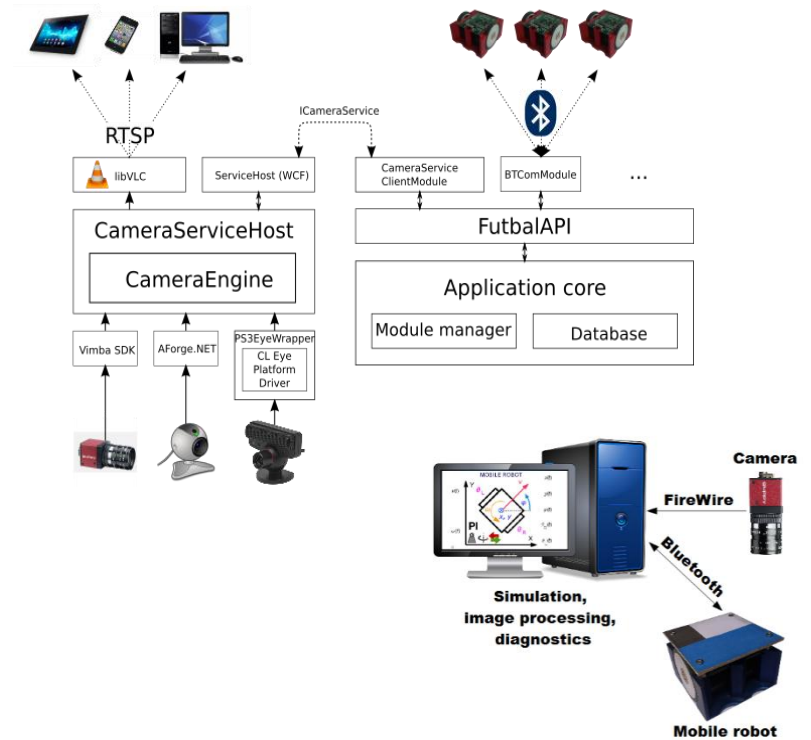

# Model applications with the implementation of camera systems

Workplace of non destructive diagnostics with linear drive

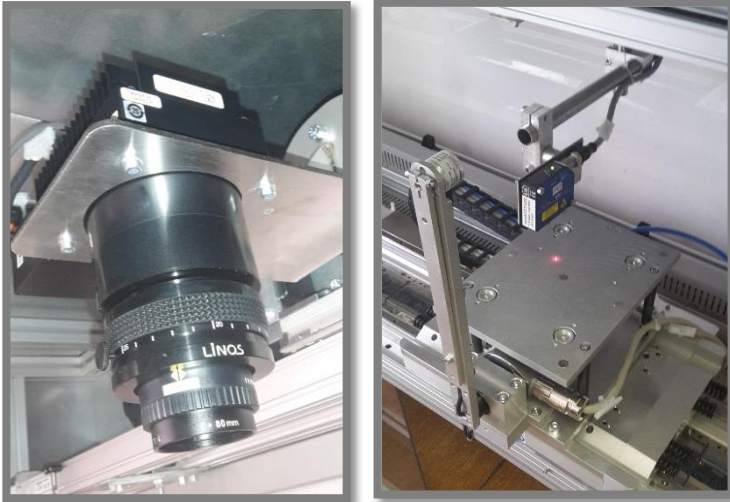

Monitoring and diagnostics of thermodynamic processes based on thermo vision camera

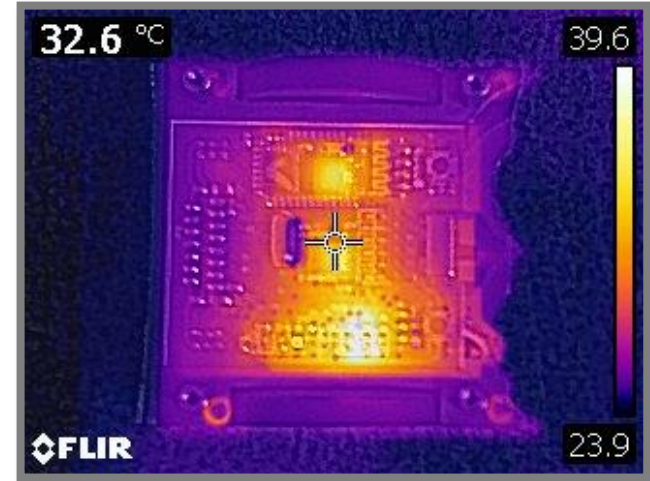

# Model applications for mechatronic systems

## Rotary inverted pendulum

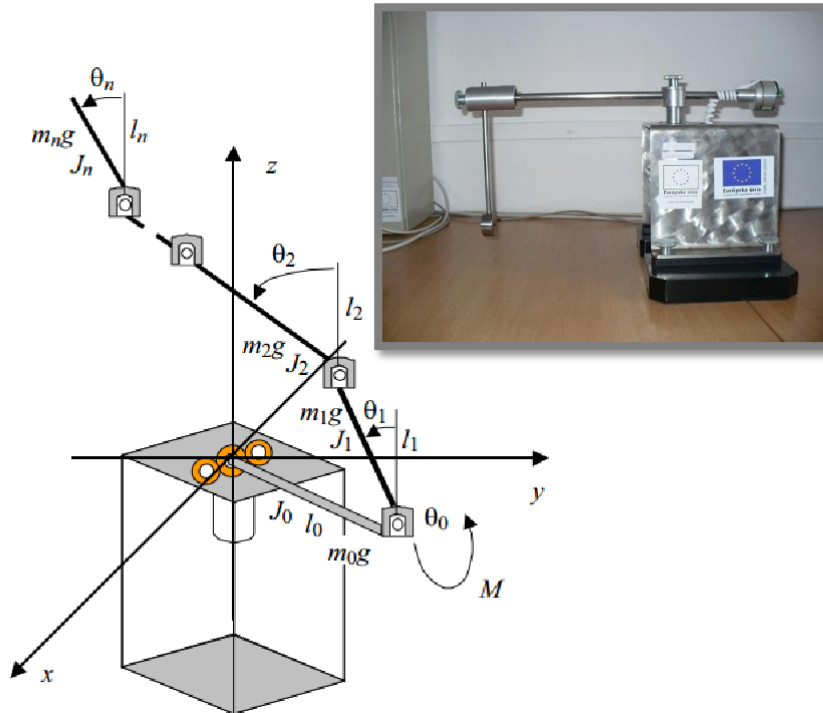

## Intelligent positioning surface

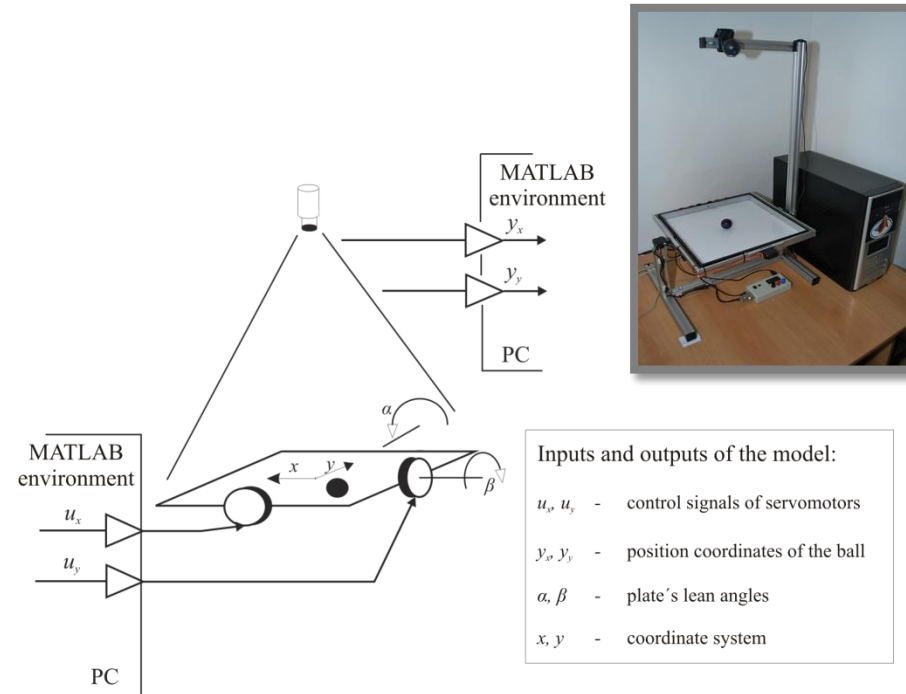

# Workplace of non destructive diagnostics with linear drive

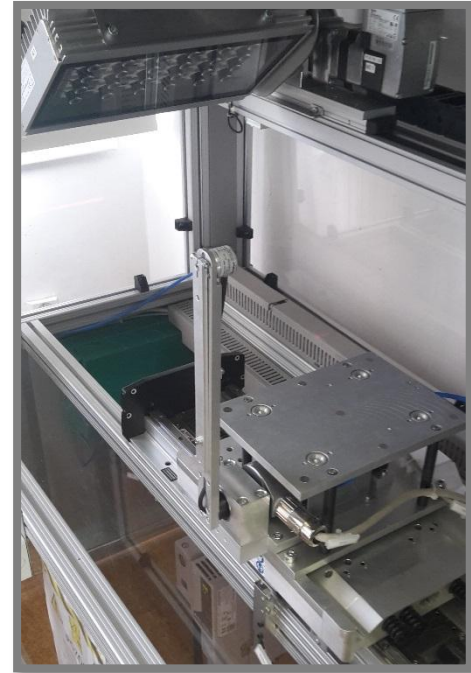
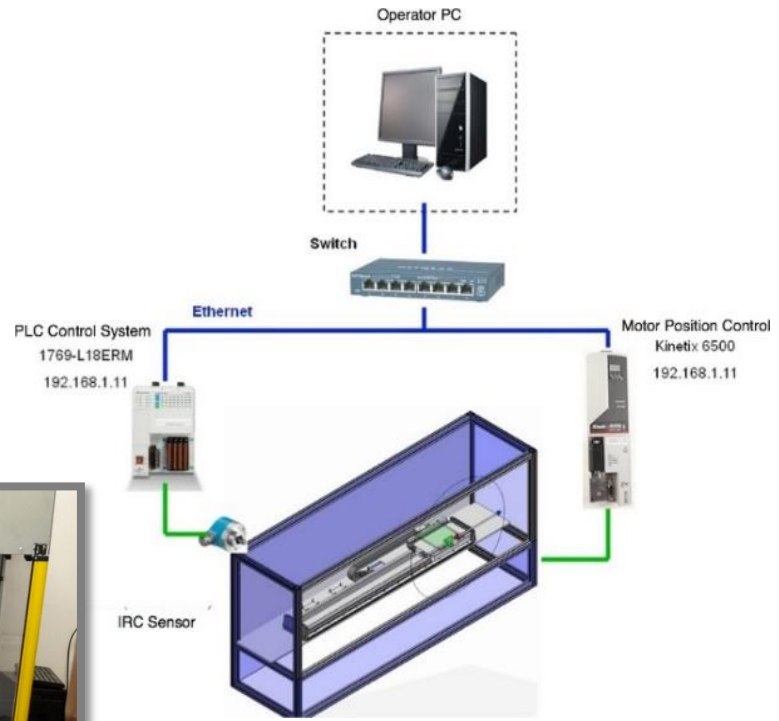



# Model applications for mechatronic systems



- Hydraulic system with frequency converter

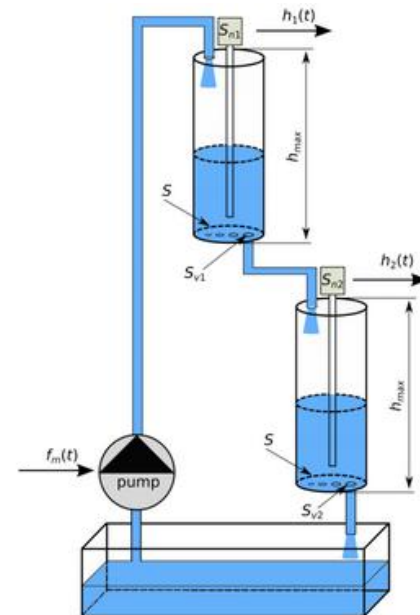

## PHYSICAL PARAMETERS:

- $S$  - intersection of tanks,
- $S_{v1}, S_{v2}$  - intersection of output valves,
- $h_{max}$  - maximal liquid level.

## PHYSICAL QUANTITIES:

- $f_m(t)$  - pump motor frequency,
- $h_1(t), h_2(t)$  - height of liquid level in tanks measured by capacitive sensors  $S_{n1}$  and  $S_{n2}$ .

# Model applications for mobile robotics

Diagnostics of sensors and actuators of robotic soccer player of MiroSot category

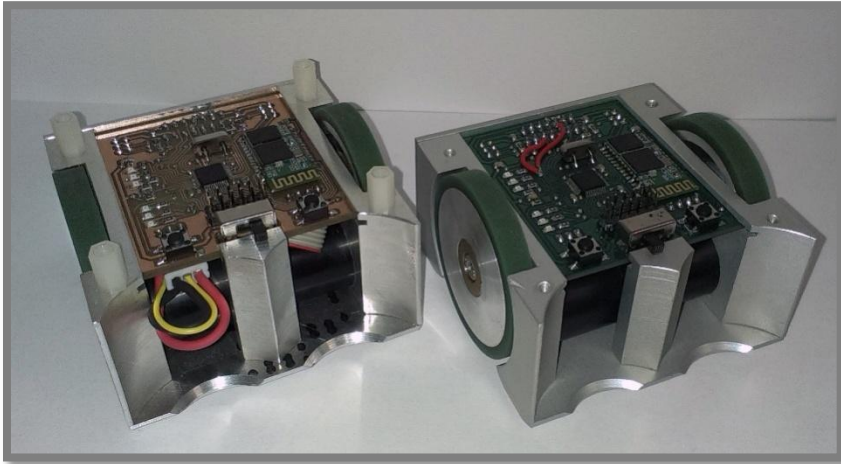

Manual and supervisory control of mobile robots

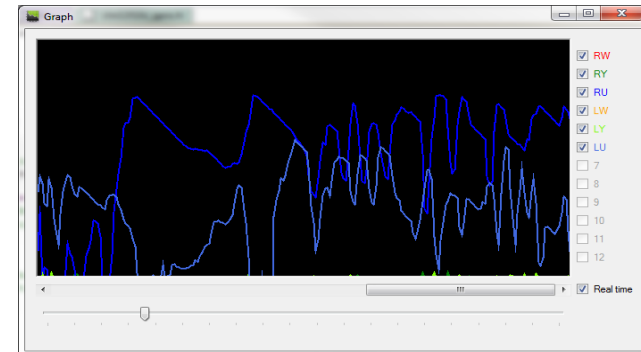
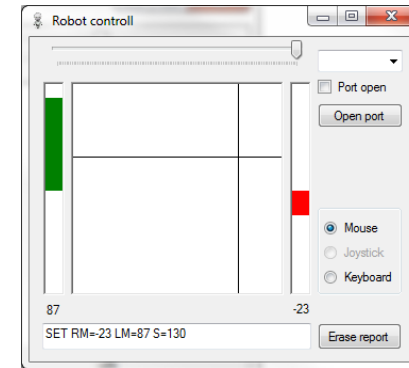

# Model applications for mobile robotics

## Robotic soccer application

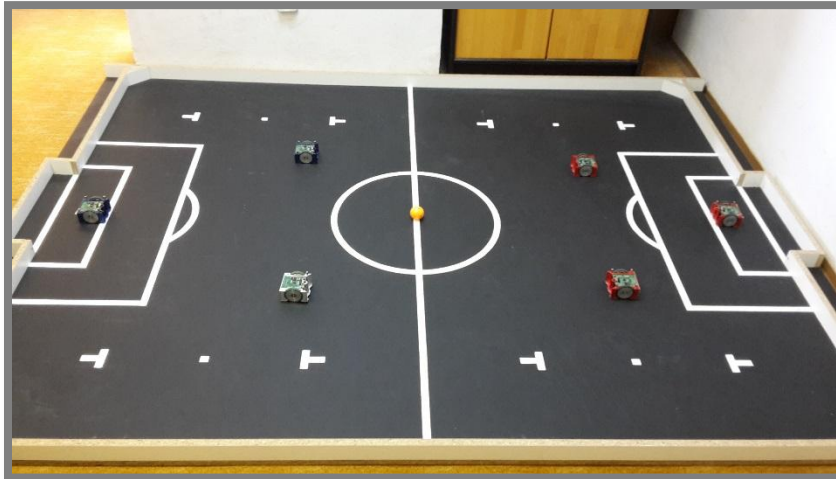
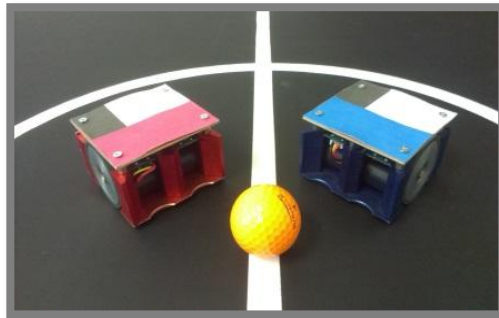

## Library of simulation models for wheeled mobile robots

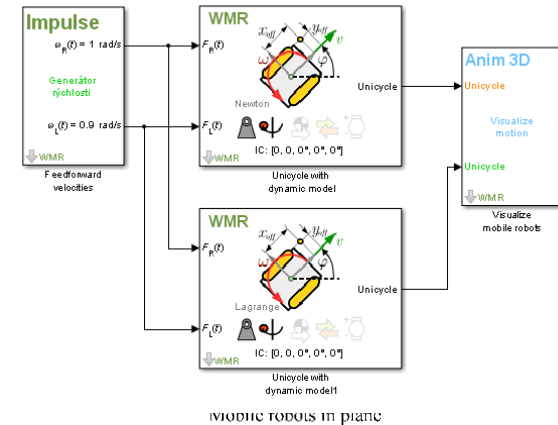

- Reference robot
- × Stop: [0.53 m, 0.63 m, 99.8°]
- Primary robot
- Start: [0 m, 0 m, 0°]
- × Stop: [0.54 m, 0.55 m, 90.9°]

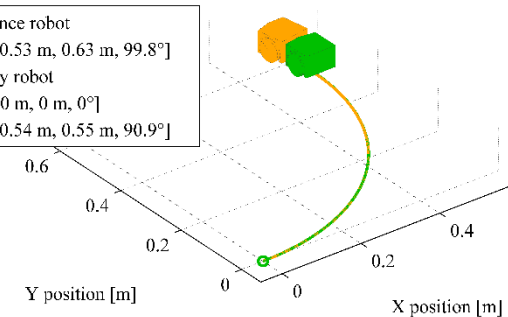

# Model applications for FAC and FMS

- Flexible assembly company and industrial robot

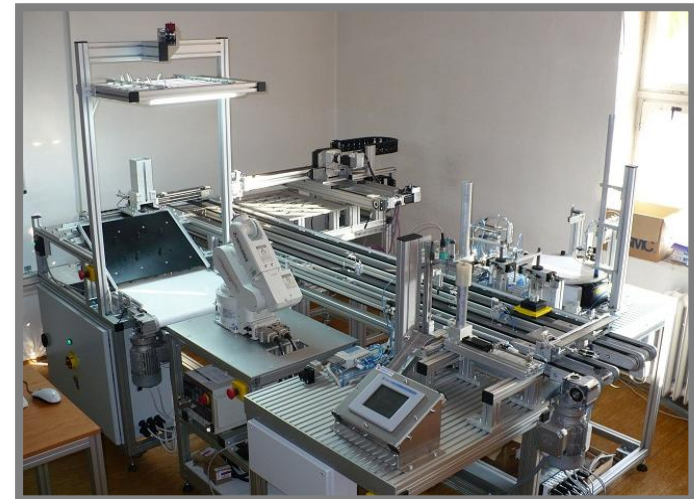
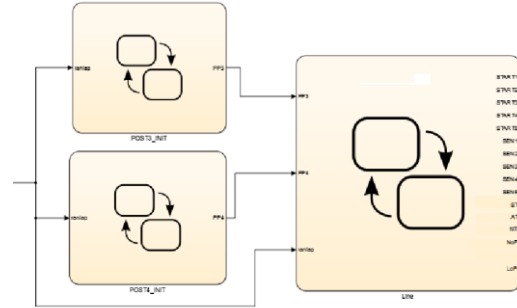
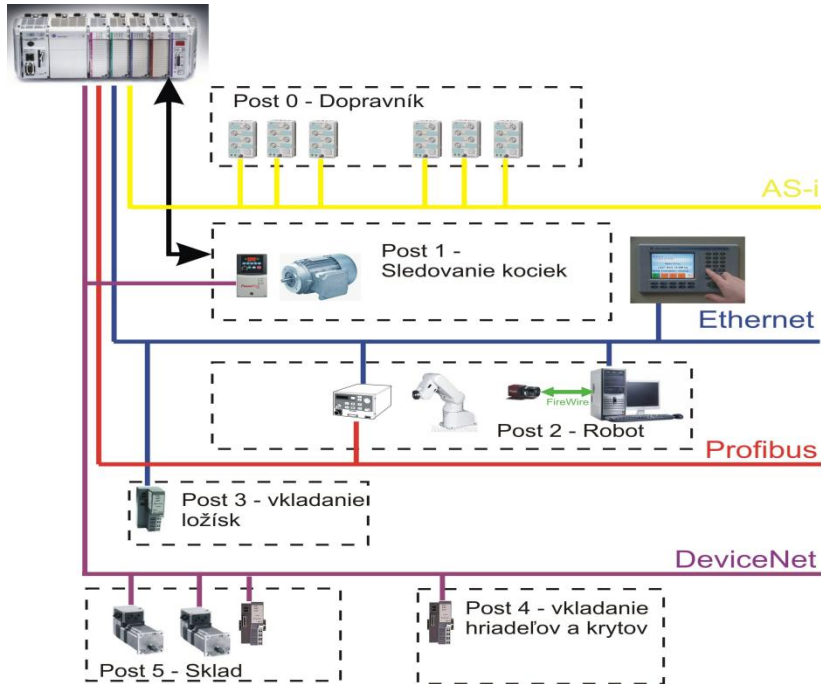

# Model applications for FAC and FMS

- Flexible manufacturing system

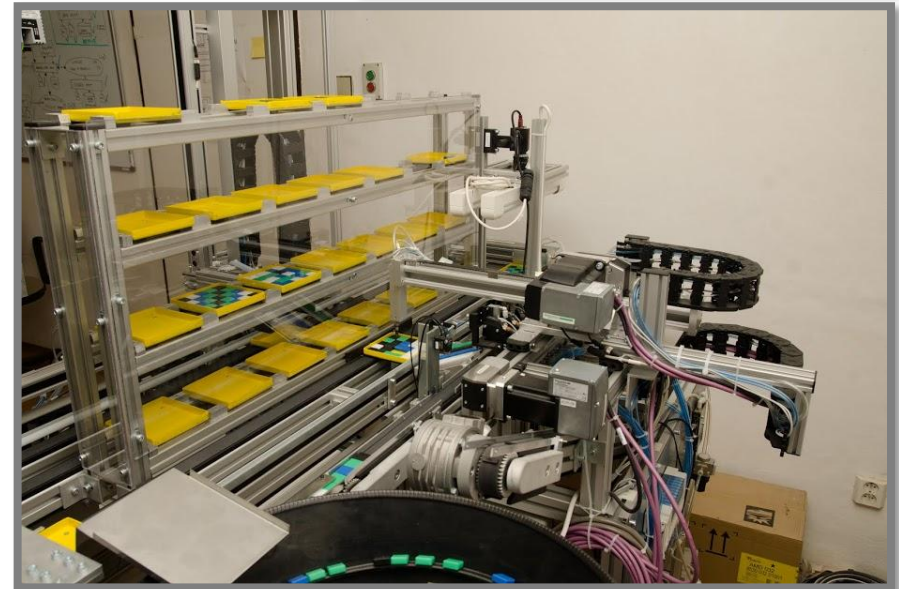
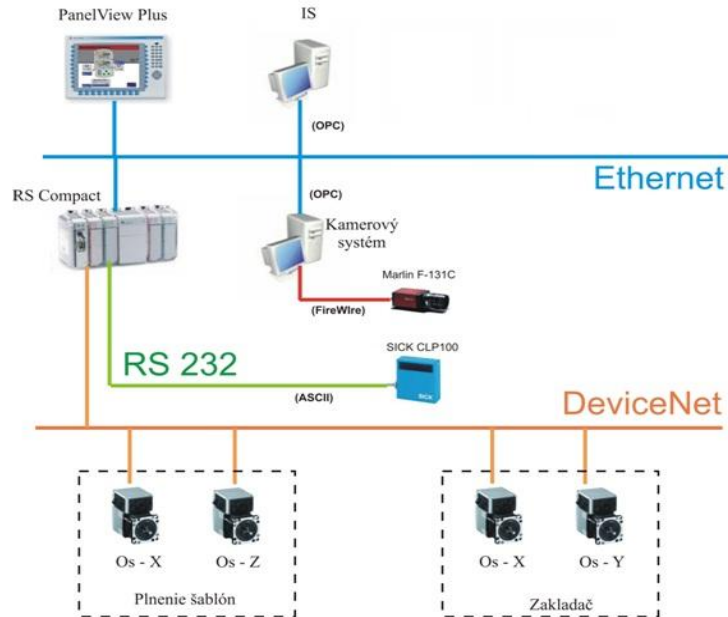

# Thank you for your attention

CMCT & II - [kyb.fei.tuke.sk](http://kyb.fei.tuke.sk)

---